

## Normas de Referência

### Construção

BSI BS EN ISO 17292  
ASME B 16.34

### Testes

API 598

## Conexões

ROSCA BSP - ISO 228  
ROSCA NPT - ANSI/ASME B 1.20.1  
SOLDA SW - ASME B 16.11  
SOLDA BW - ASME B 16.25

## Materiais

### Corpo e Tampa

ASTM A216 - WCB  
ASTM A351 - CF8  
ASTM A351 - CF8M

### Esfera

ASTM A351 - CF8  
ASTM A351 - CF8M  
ASTM A217 - CA15  
IC416  
ASTM B16 - C360

### Vedações

PTFE | COMP L

### Haste

AISI - 304  
AISI - 304L  
AISI - 316  
AISI - 316L  
AISI - 1020  
AISI - 410  
AISI - 416  
Outros materiais sob consulta



IMAGEM MERAMENTE ILUSTRATIVA

## Especificações Técnicas

Estrutura tubular desenvolvida com maior número de parafusos, proporcionando maior segurança a vazamentos externos aumentando a robustez da válvula.

Dotada de guias de apoio para alojamento dos parafusos, o que proporciona maior resistência, eliminando empenamento das tampas.

Válvula tripartida com exclusivo sistema de vedações enclausuradas que aumenta a resistência das sedes de vedação, melhorando o desempenho da válvula.

Trava para cadeado (figura 1).

## Dados Técnicos

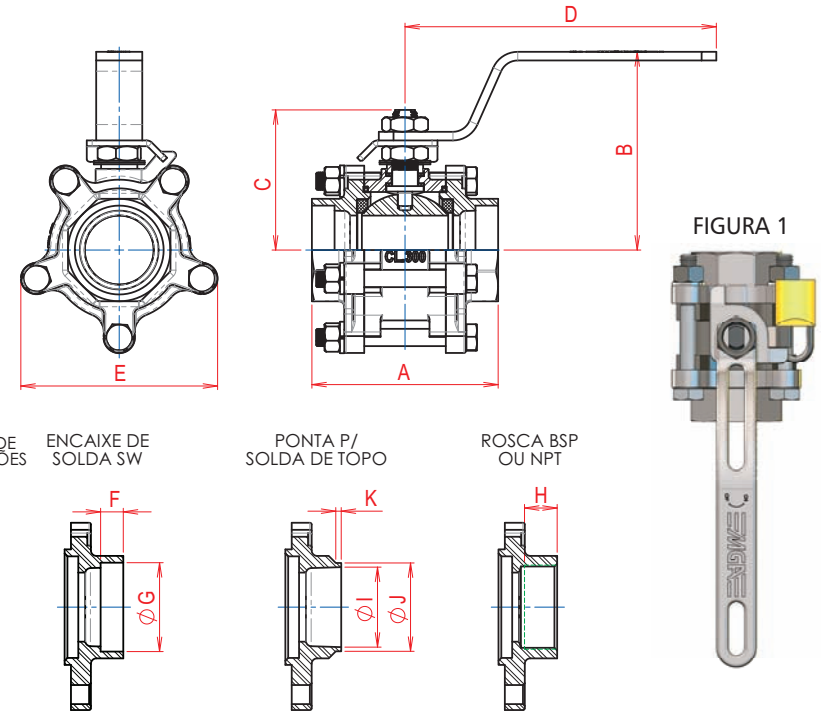

TIPOS DE CONEXÕES

ENCAIXE DE SOLDA SW

PONTA P/ SOLDA DE TOPO

ROSCA BSP OU NPT

VÁLVULA DE ESFERA TRIPARTIDA PASSAGEM REDUZIDA (PR)

BITOLA		PASS.	A	B	C	D	E	F	G	H	I	J	K	N.º DE PARAF.	PESO kg	Coeficiente de Fluxo Kv (m³/h)
POL.	DN															
1/2"	15	11,1	55,0	44,0	39,5	123,0	44,5	9,5	22,0	12,0	15,8	21,8	2,0	4	0,433	5,0
3/4"	20	14,0	64,0	46,5	41,5	123,0	48,5	12,5	27,4	14,0	20,9	27,1	2,0	4	0,546	9,8
1"	25	20,5	73,0	78,2	55,4	165,0	57,0	12,5	34,1	15,0	26,4	33,8	2,0	4	0,920	18,7
1.1/4"	32	25,4	84,0	82,0	59,0	165,0	83,0	12,5	42,9	16,0	35,0	42,6	2,0	5	1,360	42,0
1.1/2"	40	31,7	93,7	102,0	72,5	172,0	93,0	12,5	49,0	18,0	41,0	48,7	2,0	5	2,155	72,0
2"	50	38,0	108,7	109,0	77,0	172,0	108,2	16,0	61,4	20,0	52,5	61,4	3,0	5	2,855	107,0
2.1/2"	65	50,8	130,4	126,0	86,0	255,0	130,5	16,0	74,1	25,0	62,7	73,8	3,0	6	4,710	185,0
3"	80	63,0	160,2	146,0	114,0	267,0	153,0	16,0	90,5	26,0	78,0	90,1	3,0	6	8,015	305,0
4"	100	76,0	178,0	154,4	126,7	335,0	177,0	19,0	115,5	34,0	106,5	115,5	3,0	6	11,450	1050,0

VÁLVULA DE ESFERA TRIPARTIDA PASSAGEM PLENA (PP)

BITOLA		PASS.	A	B	C	D	E	F	G	H	I	J	K	N.º DE PARAF.	PESO kg	Coeficiente de Fluxo Kv (m³/h)
POL.	DN															
1/4"	8	11,1	51,0	44,0	39,5	123,0	44,5	9,5	14,4	11,0	11,1	14,0	2,0	4	0,425	5,0
3/8"	10	11,1	51,0	44,0	39,5	123,0	44,5	9,5	17,8	11,0	14,5	17,6	2,0	4	0,421	5,0
1/2"	15	14,0	60,0	46,5	41,5	123,0	48,5	9,5	22,0	12,0	18,0	21,8	2,0	4	0,508	9,8
3/4"	20	20,5	70,0	78,2	55,4	165,0	57,0	12,5	27,4	15,0	23,0	27,1	2,0	4	0,866	18,7
1"	25	25,4	82,0	82,0	59,0	165,0	83,0	12,5	34,1	16,0	29,6	33,8	2,0	5	1,310	42,0
1.1/4"	32	31,7	90,7	102,0	72,5	172,0	93,0	12,5	42,9	18,0	38,0	42,6	2,0	5	2,079	72,0
1.1/2"	40	38,0	102,7	109,0	77,0	172,0	108,2	12,5	49,0	19,0	44,1	48,7	3,0	5	2,717	107,0
2"	50	50,8	120,1	126,0	86,0	255,0	130,5	16,0	61,4	22,0	56,2	61,4	3,0	6	4,258	185,0
2.1/2"	65	63,0	152,4	146,0	114,0	267,0	153,0	16,0	74,1	27,5	70,0	73,8	3,0	6	7,593	305,0
3"	80	76,0	169,4	154,4	126,7	335,0	177,0	16,0	90,1	29,0	84,0	90,1	3,0	6	10,110	1050,0
4"	100	101,6	209,0	182,0	**	**	210,0	19,0	115,4	35,0	112,5	115,5	3,0	8	21,900	1980,0

A vazão apresentada em Kv (m³/h) corresponde a um diferencial de pressão (Δp) de 1 bar utilizando água como fluido de teste.  
\* Sob consulta, disponível com esfera oca.  
\*\* Medidas sob consulta. As válvulas de 4" PP nas configurações "AC" e "TI" e, a válvula de 3" PP na configuração "TI" estão disponíveis somente com acionamento por tubo.